



POWERING INNOVATION THAT DRIVES HUMAN ADVANCEMENT

© 2025 ANSYS, Inc. or its affiliated companies
Unauthorized use, distribution, or duplication is prohibited.

Getting Started with Icepak®: Waveguide Filter



ANSYS, Inc.
Southpointe
2600 Ansys Drive
Canonsburg, PA 15317
ansysinfo@ansys.com
<https://www.ansys.com>
(T) 724-746-3304
(F) 724-514-9494

Release 2025 R2
July 2025

ANSYS, Inc. and
ANSYS Europe,
Ltd. are UL
registered ISO
9001:2015 com-
panies.

Copyright and Trademark Information

© 1986-2025 ANSYS, Inc. Unauthorized use, distribution or duplication is prohibited.

ANSYS, Ansys Workbench, AUTODYN, CFX, FLUENT and any and all ANSYS, Inc. brand, product, service and feature names, logos and slogans are registered trademarks or trademarks of ANSYS, Inc. or its subsidiaries located in the United States or other countries. Icem CFD is a trademark used by ANSYS, Inc. under license. All other brand, product, service and feature names or trademarks are the property of their respective owners. FLEXIm and FLEXnet are trademarks of Flexera Software LLC.

Disclaimer Notice

THIS ANSYS SOFTWARE PRODUCT AND PROGRAM DOCUMENTATION INCLUDE TRADE SECRETS AND ARE CONFIDENTIAL AND PROPRIETARY PRODUCTS OF ANSYS, INC., ITS SUBSIDIARIES, OR LICENSORS. The software products and documentation are furnished by ANSYS, Inc., its subsidiaries, or affiliates under a software license agreement that contains provisions concerning non-disclosure, copying, length and nature of use, compliance with exporting laws, warranties, disclaimers, limitations of liability, and remedies, and other provisions. The software products and documentation may be used, disclosed, transferred, or copied only in accordance with the terms and conditions of that software license agreement.

ANSYS, Inc. and ANSYS Europe, Ltd. are UL registered ISO 9001: 2015 companies.

U.S. Government Rights

For U.S. Government users, except as specifically granted by the ANSYS, Inc. software license agreement, the use, duplication, or disclosure by the United States Government is subject to restrictions stated in the ANSYS, Inc. software license agreement and FAR 12.212 (for non-DOD licenses).

Third-Party Software

See the legal information in the product help files for the complete Legal Notice for Ansys proprietary software and third-party software. If you are unable to access the Legal Notice, please contact ANSYS, Inc.

Conventions Used in this Guide

Please take a moment to review how instructions and other useful information are presented in this documentation.

- Procedures are presented as numbered lists. A single bullet indicates that the procedure has only one step.
- Bold type is used for the following:
 - Keyboard entries that should be typed in their entirety exactly as shown. For example, “**copy file1**” means you must type the word **copy**, then type a space, and then type **file1**.
 - On-screen prompts and messages, names of options and text boxes, and menu commands. Menu commands are often separated by greater than signs (>). For example, “click **HFSS > Excitations > Assign > Wave Port.**”
 - Labeled keys on the computer keyboard. For example, “Press **Enter**” means to press the key labeled **Enter**.
- Italic type is used for the following:
 - Emphasis.
 - The titles of publications.
 - Keyboard entries when a name or a variable must be typed in place of the words in italics. For example, “**copy filename**” means you must type the word **copy**, then type a space, and then type the name of the file.
- The plus sign (+) is used between keyboard keys to indicate that you should press the keys at the same time. For example, “Press Shift+F1” means to press the **Shift** key and, while holding it down, press the **F1** key also. You should always depress the modifier key or keys first (for example, Shift, Ctrl, Alt, or Ctrl+Shift), continue to hold it/them down, and then press the last key in the instruction.

Accessing Commands: *Ribbons*, *menu bars*, and *shortcut menus* are three methods that can be used to see what commands are available in the application.

- The *Ribbon* occupies the rectangular area at the top of the application window and contains multiple tabs. Each tab has relevant commands that are organized, grouped, and labeled. An example of a typical user interaction is as follows:

"Click **Draw > Line**"



This instruction means that you should click the **Line** command on the **Draw** ribbon tab. An image of the command icon, or a partial view of the ribbon, is often included with the instruction.

- The *menu bar* (located above the ribbon) is a group of the main commands of an application arranged by category such File, Edit, View, Project, etc. An example of a typical user interaction is as follows:

"On the **File** menu, click the **Open Examples** command" means you can click the **File** menu and then click **Open Examples** to launch the dialog box.

- Another alternative is to use the *shortcut menu* that appears when you click the right-mouse button. An example of a typical user interaction is as follows:

"Right-click and select **Assign Excitation> Wave Port**" means when you click the right-mouse button with an object face selected, you can execute the excitation commands from the shortcut menu (and the corresponding sub-menus).

Getting Help: Ansys Technical Support

For information about Ansys Technical Support, go to the Ansys corporate Support website, <http://www.ansys.com/Support>. You can also contact your Ansys account manager in order to obtain this information.

All Ansys software files are ASCII text and can be sent conveniently by e-mail. When reporting difficulties, it is extremely helpful to include very specific information about what steps were taken or what stages the simulation reached, including software files as applicable. This allows more rapid and effective debugging.

Help Menu

To access help from the Help menu, click **Help** and select from the menu:

- **[product name] Help** - opens the contents of the help. This help includes the help for the product and its *Getting Started Guides*.
- **[product name] Scripting Help** - opens the contents of the *Scripting Guide*.
- **[product name] Getting Started Guides** - opens a topic that contains links to Getting Started Guides in the help system.

Context-Sensitive Help

To access help from the user interface, press **F1**. The help specific to the active product (design type) opens.

You can press **F1** while the cursor is pointing at a menu command or while a particular dialog box or dialog box tab is open. In this case, the help page associated with the command or open dialog box is displayed automatically.

Table of Contents

Table of Contents	Contents-1
1 - Introduction	1-1
2 - Run the HFSS Simulation	2-1
Open the Project	2-1
Launch the Ansys Electronics Desktop	2-1
Set 3D UI Options	2-2
Review the HFSS Design	2-2
Analyze the Design and Report Surface Losses	2-4
3 - Prepare and Run the Icepak Simulation	3-1
Set Up the Icepak Design	3-1
Assign Thermal Boundary Conditions	3-4
Assign the Inlet Opening	3-4
Assign the Outlet Opening	3-6
Assign the EM Surface Loss	3-6
Set Solution Type	3-7
Create a Point Monitor	3-8
Define Icepak Design Settings	3-10
Add a Solution Setup	3-11
Generate a Global Mesh	3-11
View Global Mesh Settings	3-11
Generate and Examine the Mesh	3-11
Generate the Refined Mesh	3-12
Edit Global Mesh Settings	3-12
Generate and Examine the Mesh	3-13
Run the Icepak Simulation	3-14
4 - Postprocess the Icepak Simulation	4-1
Create Field Plots	4-1
Create a Temperature Field Plot	4-1

Create a Velocity Field Plot	4-2
Create a Fields Summary	4-2

1 - Introduction

This document is intended as supplementary material to Icepak for beginners and advanced users. It includes instructions to analyze an HFSS project, calculate surface losses, and create and solve an Icepak design based on the same geometry.

This chapter contains the following topic:

- "Sample Project - The Waveguide Filter" below

Sample Project - The Waveguide Filter

In this project, you will learn how to import the waveguide filter model. HFSS calculates the RF losses in the waveguide, and Icepak solves for thermal fields.

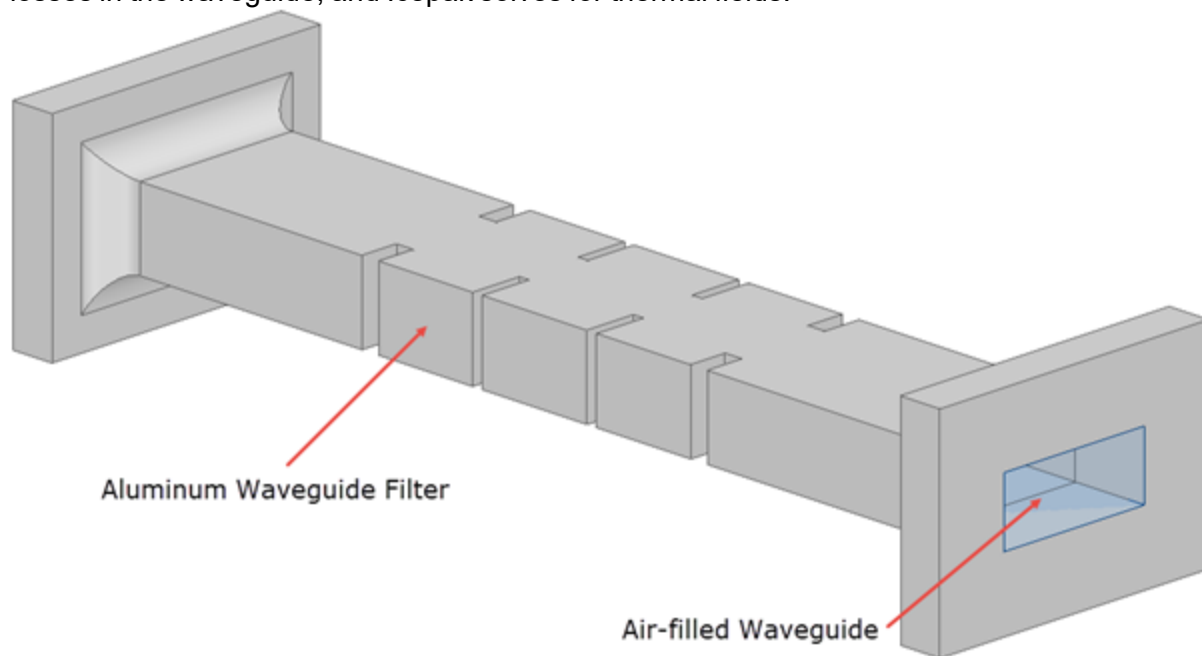

Figure 1-1: Waveguide Filter

2 - Run the HFSS Simulation

This chapter contains the following topic:

- [Open the Project](#)
- [Review the HFSS Design](#)
- [Analyze the HFSS Design and Report Losses](#)



Open the Project

This chapter contains the following topics:

- Launch the Ansys Electronics Desktop

Launch the Ansys Electronics Desktop

A shortcut of the Ansys Electronics Desktop application appears on your desktop once the application is installed.

1. On the **Desktop** ribbon tab, click  **Open Examples**. Then:
 - a. In the *Open* dialog box that appears, click the parent folder icon () once to move up one level above the *Examples* folder.
 - b. Double-click the **Help** folder and then the **Icepak** folder.
 - c. Select the file **Waveguide_Filter_HFSS.aedt** and click **Open**.
2. The model is displayed in the **3D Modeler** window.

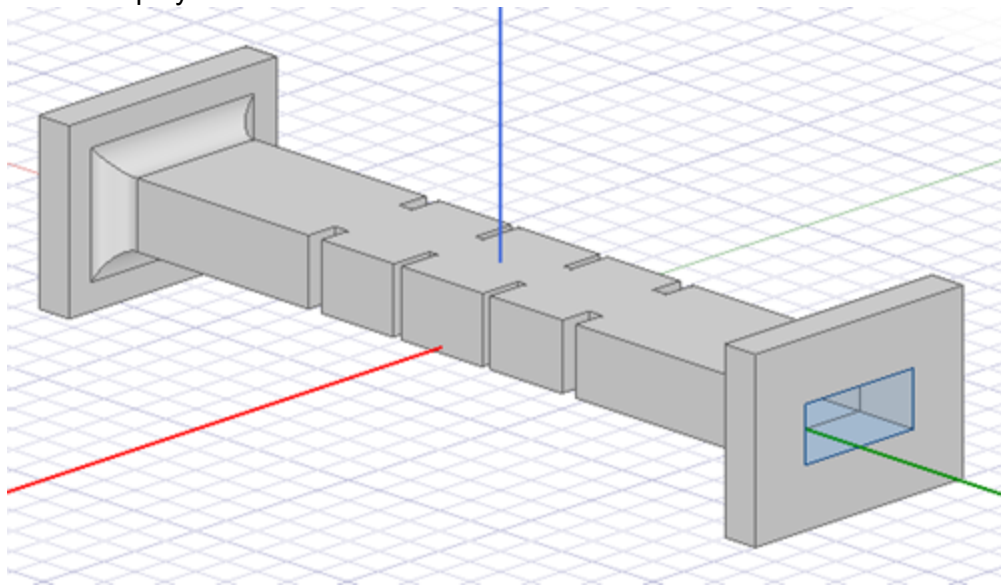

Figure 2-1: Waveguide filter model in the 3D Modeler window

3. From the **File** menu, select **Save As**, and save the project in the desired working directory.

Set 3D UI Options

Ensure that the new view orientation scheme introduced in release 2024 R1 is not being used, since the instructions and images in this guide are based on the legacy orientation scheme.

1. From the menu bar, click **View > Options**.
The *3D UI Options* dialog box appears.
2. Ensure that **Enable Legacy View Orientation** is enabled:

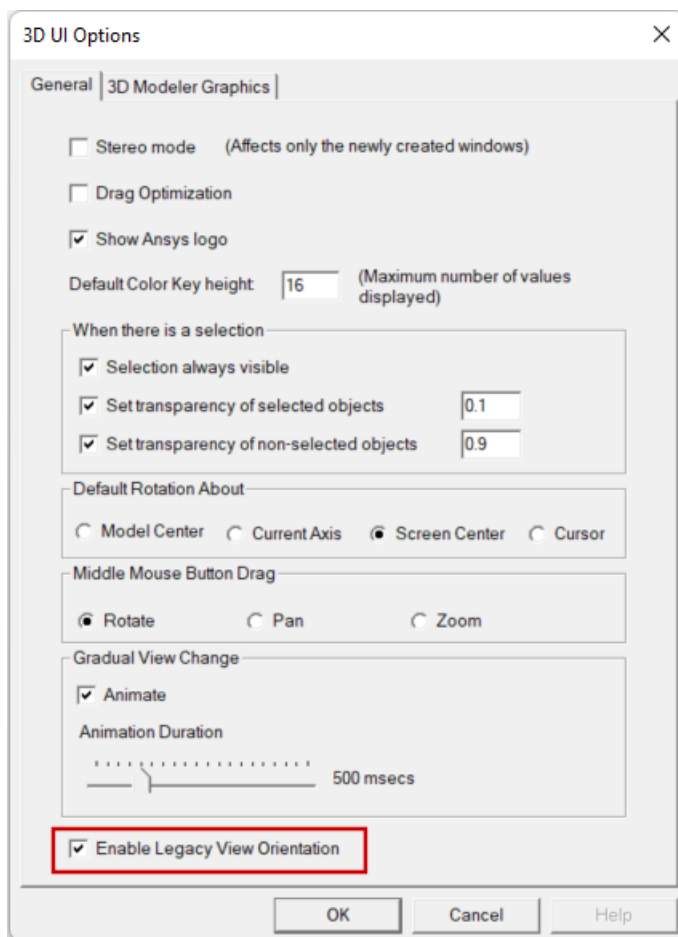

3. Click **OK**.

Review the HFSS Design

1. In the history tree, expand **Model > Solids > Aluminum** and review the component geometry.

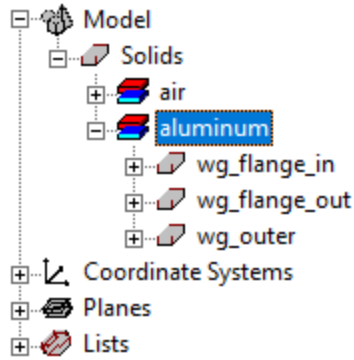

Figure 2-2: History tree

- From the **HFSS** menu, select **Fields > Edit Sources** to review the sources.

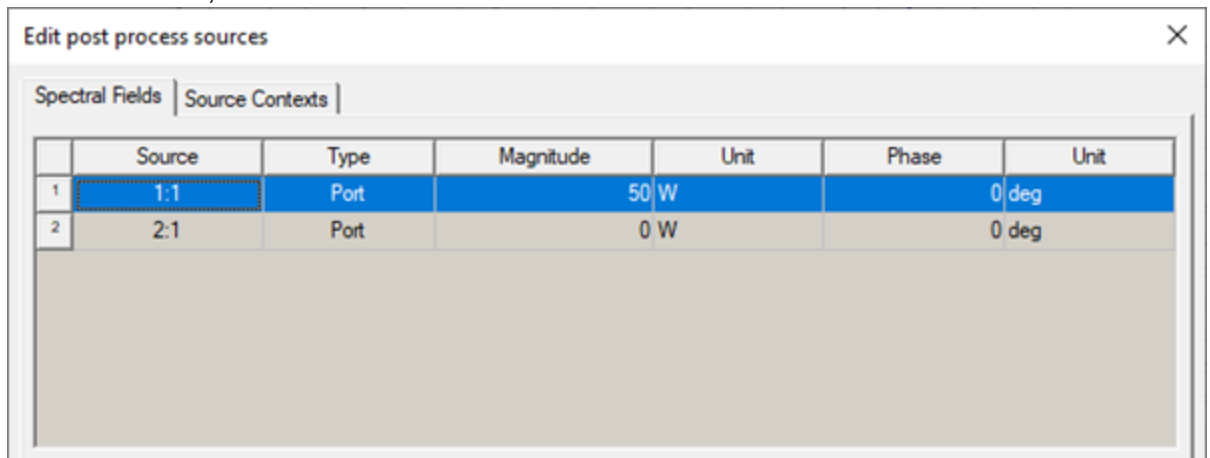
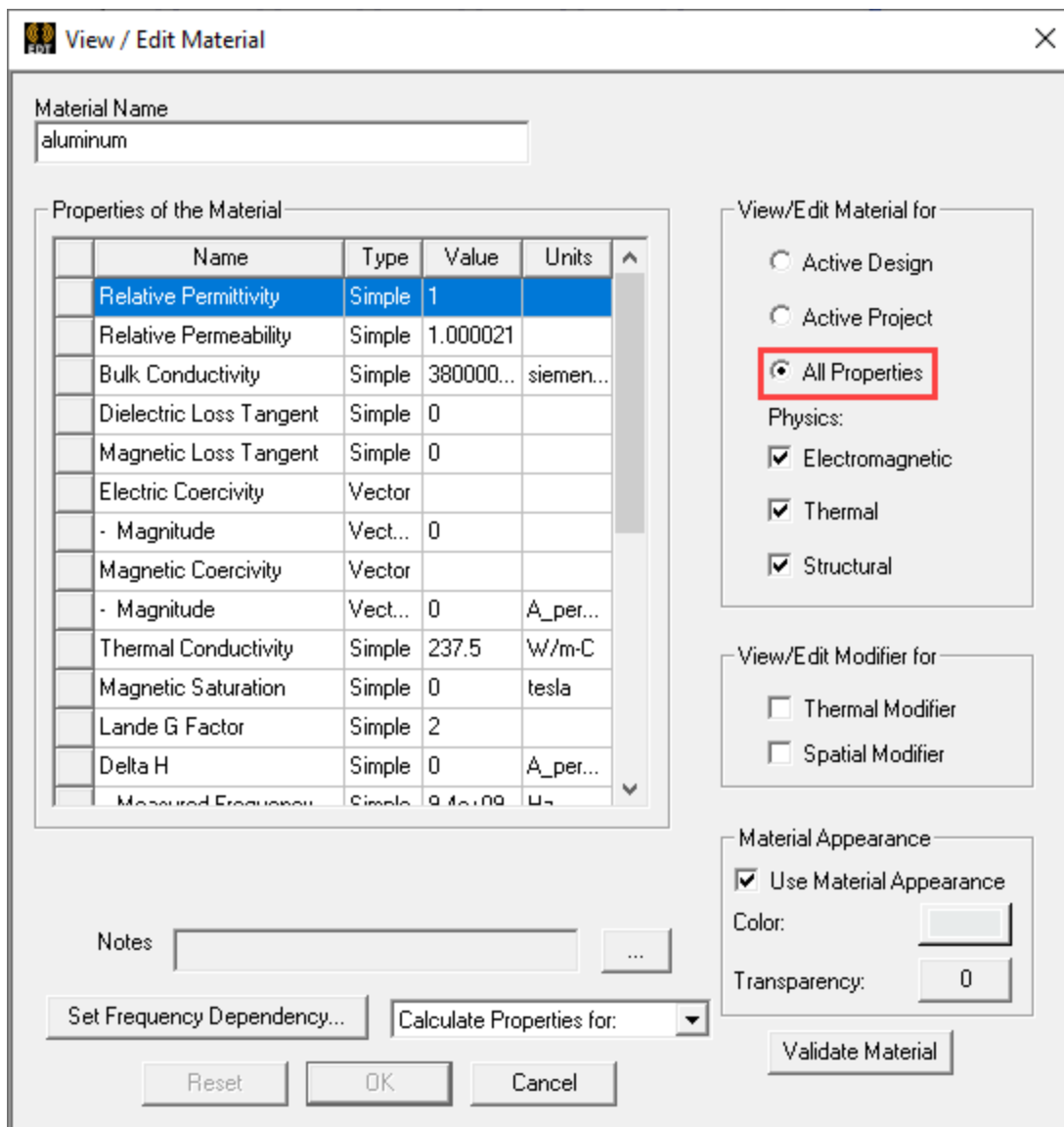

Figure 2-3: Edit post process sources dialog box

Note: Port 1 is excited by 50 W.

- Click **Cancel** to close the **Edit post process sources** dialog box.
- In the **Project Manager**, expand **Definitions > Materials** and double-click on aluminum to open the **View/Edit Material** dialog box.
- Enable **All Properties** to view the material properties used in electromagnetic, thermal, and structural simulations.



6. Click **Cancel** to close the dialog box.

Analyze the Design and Report Surface Losses

1. In the **Project Manager**, expand **Analysis**.
2. Right-click on the solution setup (*Setup1*) and select **Analyze** to run the HFSS simulation.
3. Right-click Setup1 and select **Convergence**.
4. Change the **View** to **Plot** and review the convergence statistics in the convergence table and plot.

Note: When the simulation is complete, a message is displayed in the **Message Manager** indicating normal completion.

5. After the simulation is complete and you're finished reviewing the convergence statistics, click **Close**.
6. In the history tree, select *wg_flange_in*, *wg_flange_out*, and *wg_outer*.
7. On the **Model** ribbon, click **New object List** to create an object list to be used in the Fields Calculator. *Objectlist1* appears under **Lists** in the history tree.

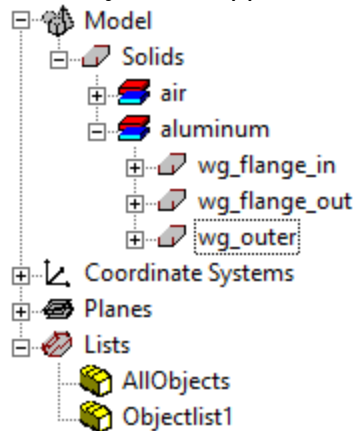

Figure 2-4: History tree - Objectlist1

8. From the **HFSS** menu, select **Fields > Calculator** to open the **Fields Calculator**.
9. Under **Input**, click **Quantity** and select **SurfaceLossDensity**.
10. Click **Geometry**, select **Surface**, select **Objectlist1**, and click **OK**.
11. Under **Scalar**, click **Integrate** (\int).
12. Under **Output**, click **Eval**. The surface loss is calculated.

Note: The EM loss is displayed in Watts.

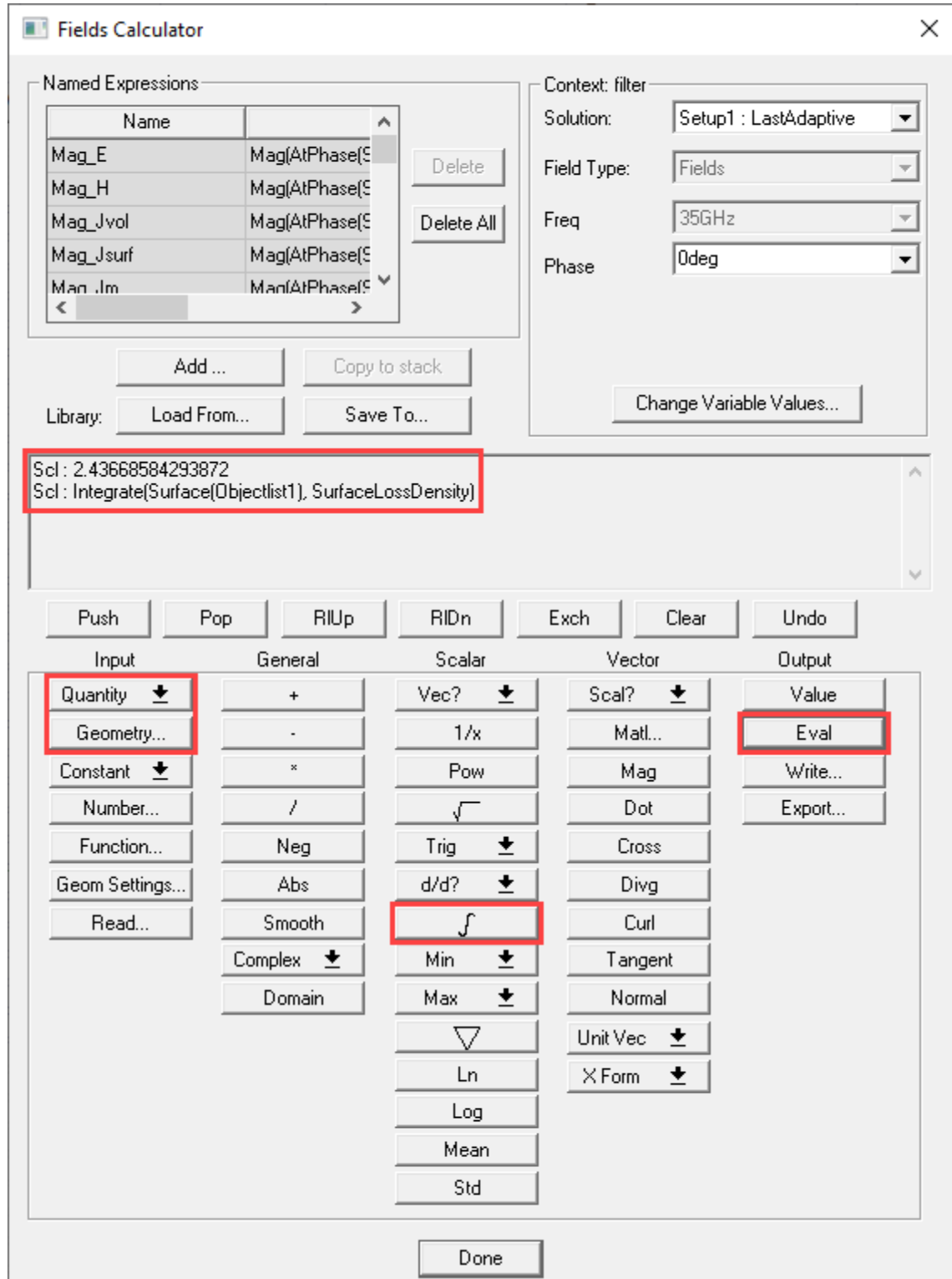

Figure 2-5: Fields Calculator

13. Verify the results and click **Done** to close the **Fields Calculator**.

14. From the **File** menu, select **Save**.

3 - Prepare and Run the Icepak Simulation

This chapter contains the following topic:

- [Set Up the Icepak Design](#)
- [Assign Thermal Boundary Conditions](#)
- [Set Solution Type](#)
- [Define Design Settings](#)
- [Add a Solution Setup](#)
- [Generate a Global Mesh](#)
- [Generate the Refined Mesh](#)

Set Up the Icepak Design

1. In the history tree, right-click **Model** and select **Select All**.

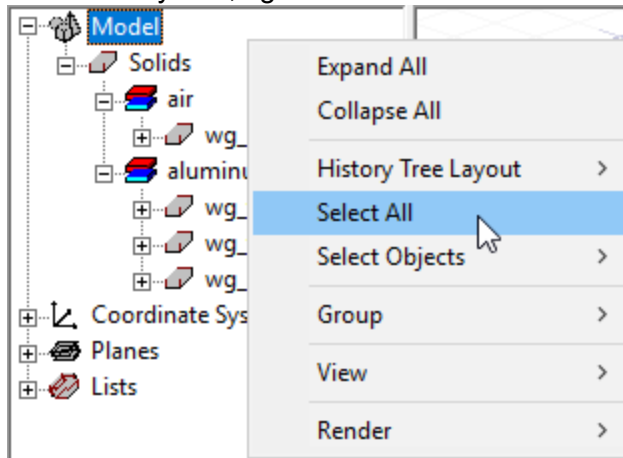

2. From the **Edit** menu, select **Copy**. Alternatively, you can press **Ctrl + C** to copy the geometry.
3. From the **Project** menu, select **Insert Icepak Design**.

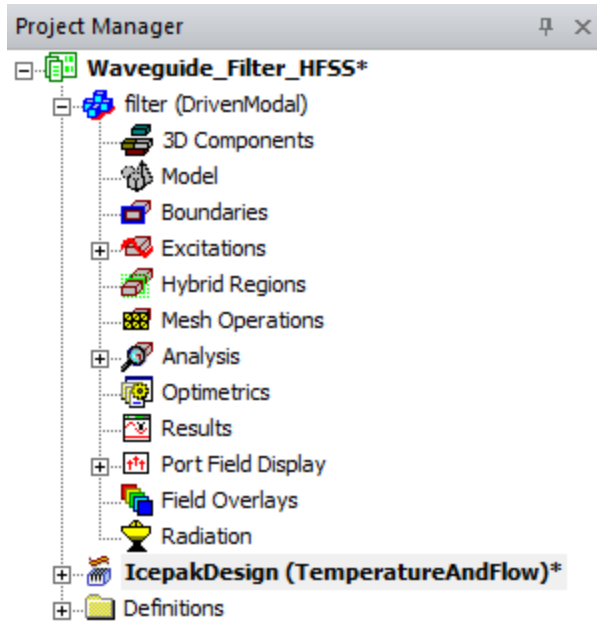

Figure 3-1: Project Manager

4. Right-click in the **3D Modeler** window and select **Edit > Paste**. The geometry from the HFSS design is inserted into the Icepak design. Alternatively, you can press **Ctrl + V** to paste the geometry.
5. On the **Draw** ribbon, click **Fit All**. Alternatively, you can press **Ctrl + D** to fit the geometry.

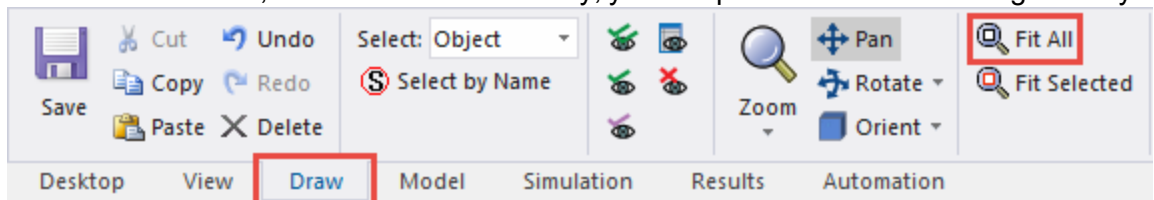

Figure 3-2: Draw ribbon - Fit All

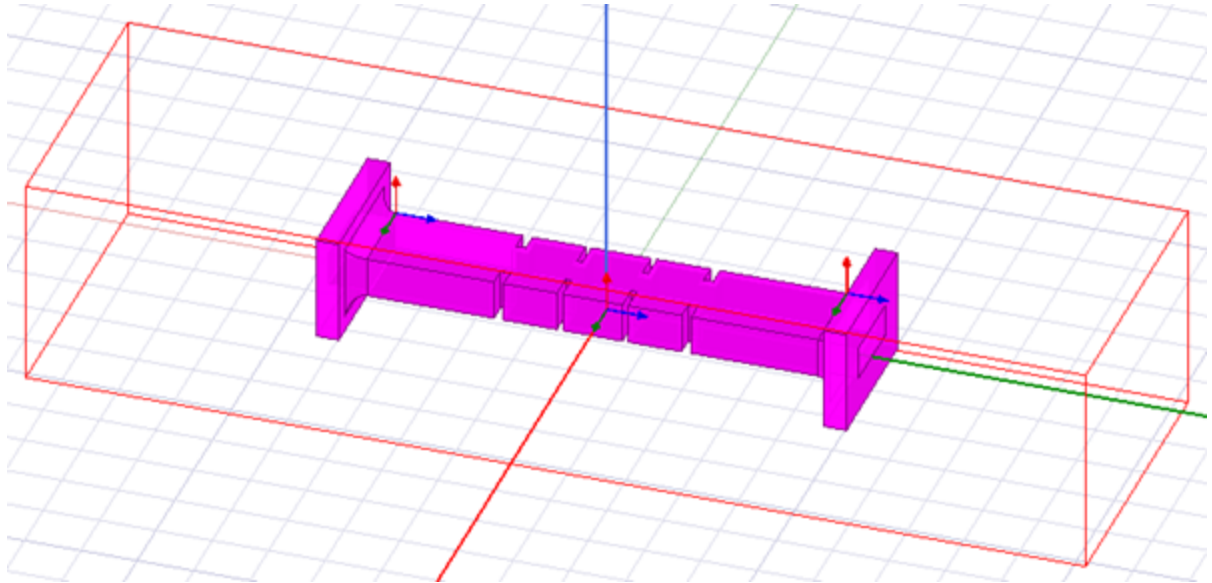

Figure 3-3: Waveguide Filter Geometry in Icepak Design

Note: The Region geometry (computational domain) is automatically created.

6. In the history tree, right-click *air* and select **Properties** to examine the thermal material properties.
7. Change the material to fluid air by selecting **Air(@300K)** and clicking **OK**.

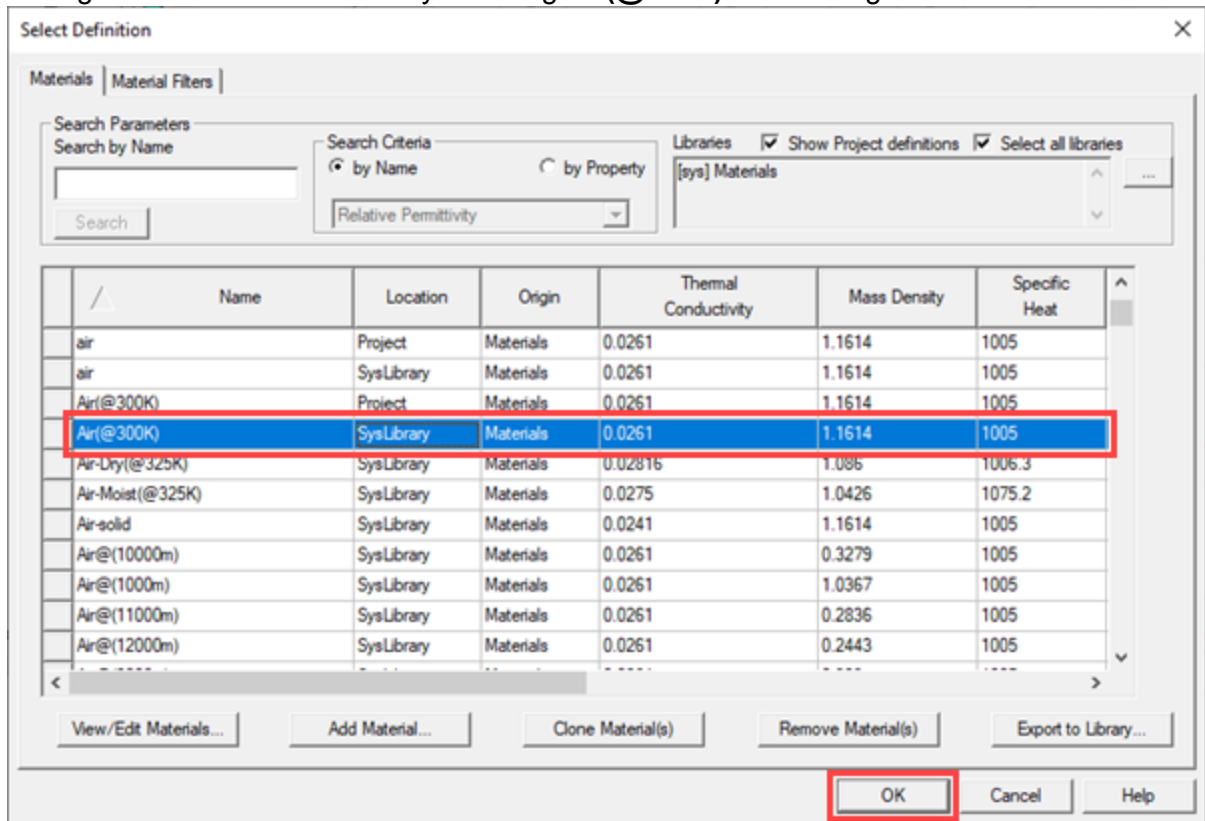

Figure 3-4: Select Definition dialog box

- To ensure that the appropriate geometry is included in the analysis, select *wg_outer*, *wg_flange_in*, and *wg_flange_out* in the history tree and ensure that **Solve Inside** is enabled in the **Properties** window.

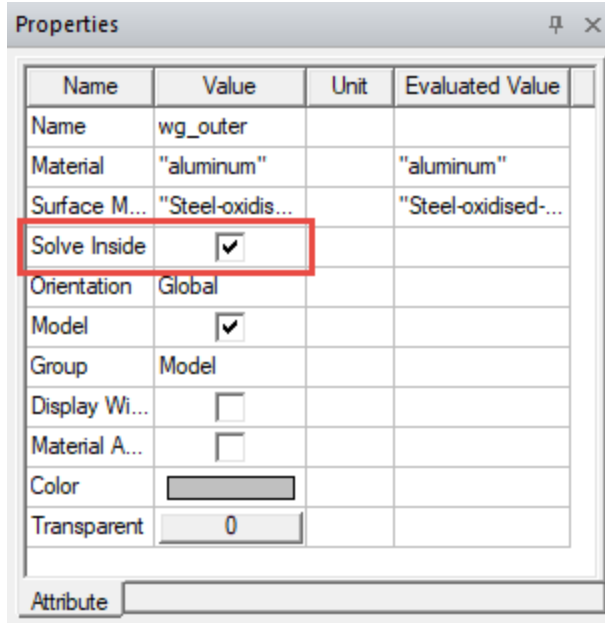

Figure 3-5: Properties window - wg_outer

Assign Thermal Boundary Conditions

Assign the Inlet Opening

- Press F to enter face selection mode.

Note: When selecting faces, you can press the B key to select the face immediately behind your initial selection.

- In the **3D Modeler** window select the min Y side of the Region geometry.

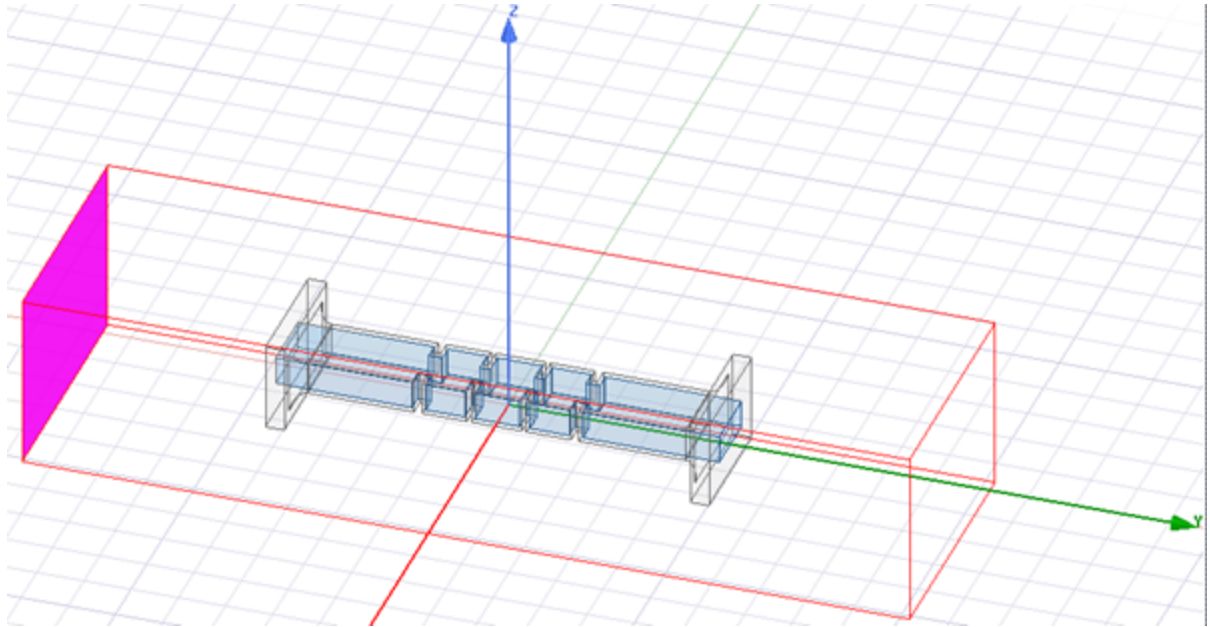

Figure 3-6: Min Y side of Region geometry

3. Right-click in the **3D Modeler** window and select **Assign Thermal > Opening > Free**.
4. Enter *Inlet* as the **Name**.
5. Under **Flow Specification**, select **Velocity** for **Inlet Type**.
6. For **Y Velocity**, enter 1 and retain the unit as **m_per_sec**.
7. Click **OK**.

Assign the Outlet Opening

1. In the **3D Modeler** window select the max Y side of the Region geometry.

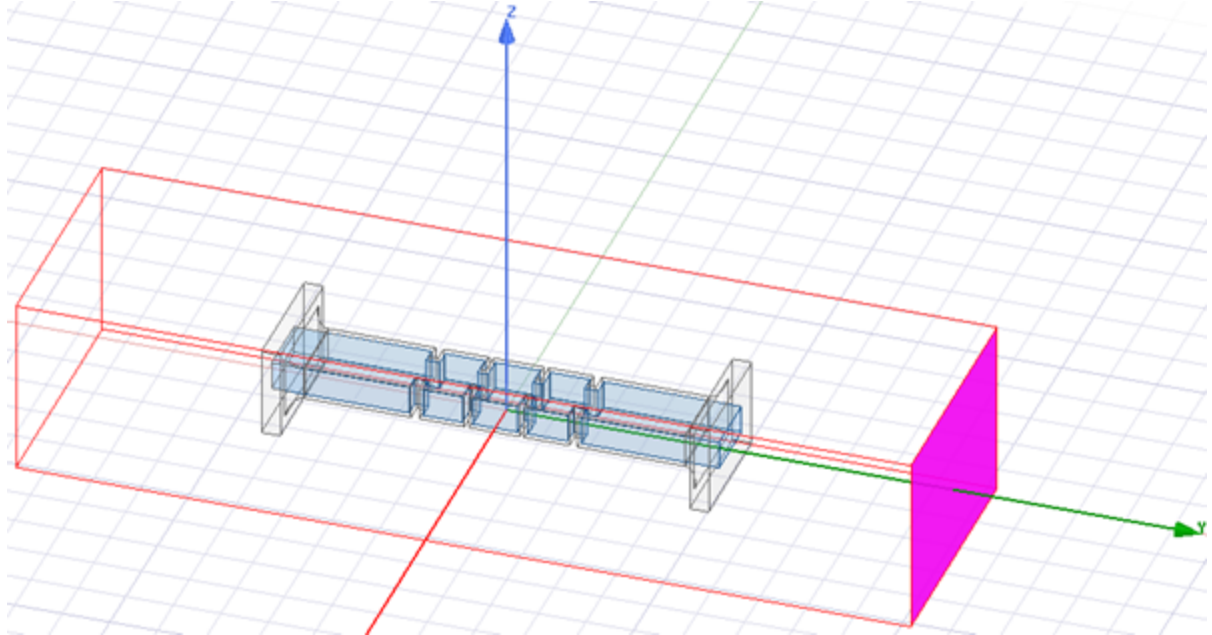

Figure 3-7: Max Y side of Region geometry

2. Right-click in the **3D Modeler** window and select **Assign Thermal > Opening > Free**.
3. Enter *Outlet* as the **Name**.
4. Retain the default settings and click **OK**.

Assign the EM Surface Loss

1. In the history tree, select *wg_flange_in*, *wg_flange_out*, and *wg_outer* using the Shift key.

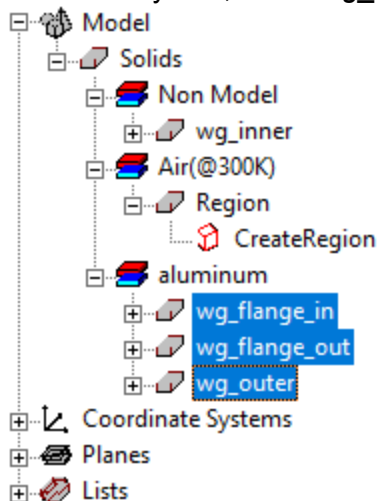
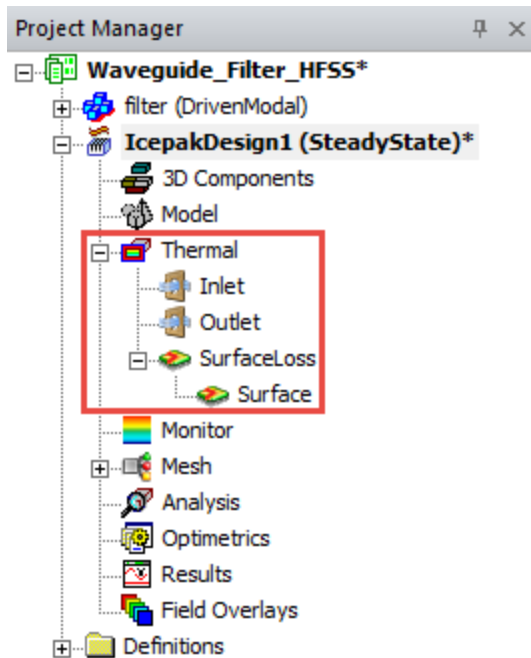

Figure 3-8: History tree - EM loss selection

2. Right-click in the **3D Modeler** window and select **Assign Thermal > EM Loss**.
3. In the **Setup Link** dialog box, select the **Use This Project** check box.
4. On the **Variable Mapping** tab, click **Map Variable by Name** to compare the source design variables to the Icepak design variables. Any variables with the same name are mapped so that the source design conforms to the Icepak design.
5. Click **OK**.
6. In the **EM Loss** dialog box, enter *SurfaceLoss* as the **Name**.
7. Ensure the *wg_flange_in*, *wg_flange_out*, and *wg_outer* are listed under **Surface**. If they are not, drag them under **Surface** to designate a surface loss.
8. Click **OK**.

**Figure 3-9: Project Manager - Thermal Boundary Conditions**

9. From the **File** menu, select **Save**.

Set Solution Type

Specify the design's solution type as follows:

1. Click **Icepak>Solution Type**.
The **Solution Type** dialog box appears.
2. Ensure that **Steady State** and **Temperature and Flow** are selected and click **OK**.

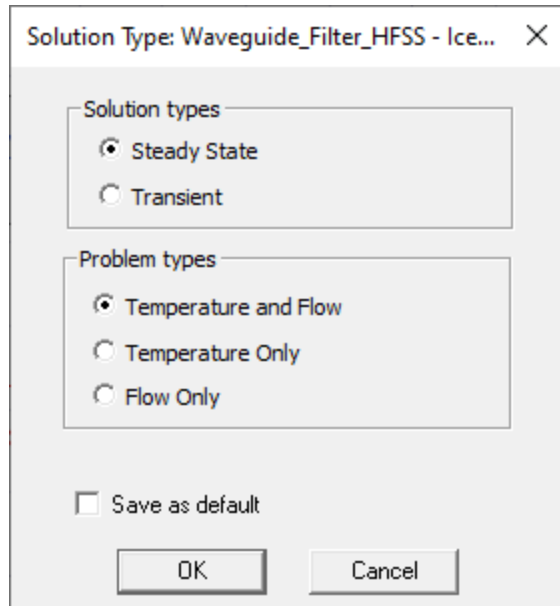



Figure 3-10: Solution Type

Create a Point Monitor

To check the temperature of a specified point during a solution, create a point and assign a point monitor to it.

1. On the **Draw** ribbon, click the **Draw Point** button .
2. In the **3D Modeler** window, click the top center point of *wg_outer*.

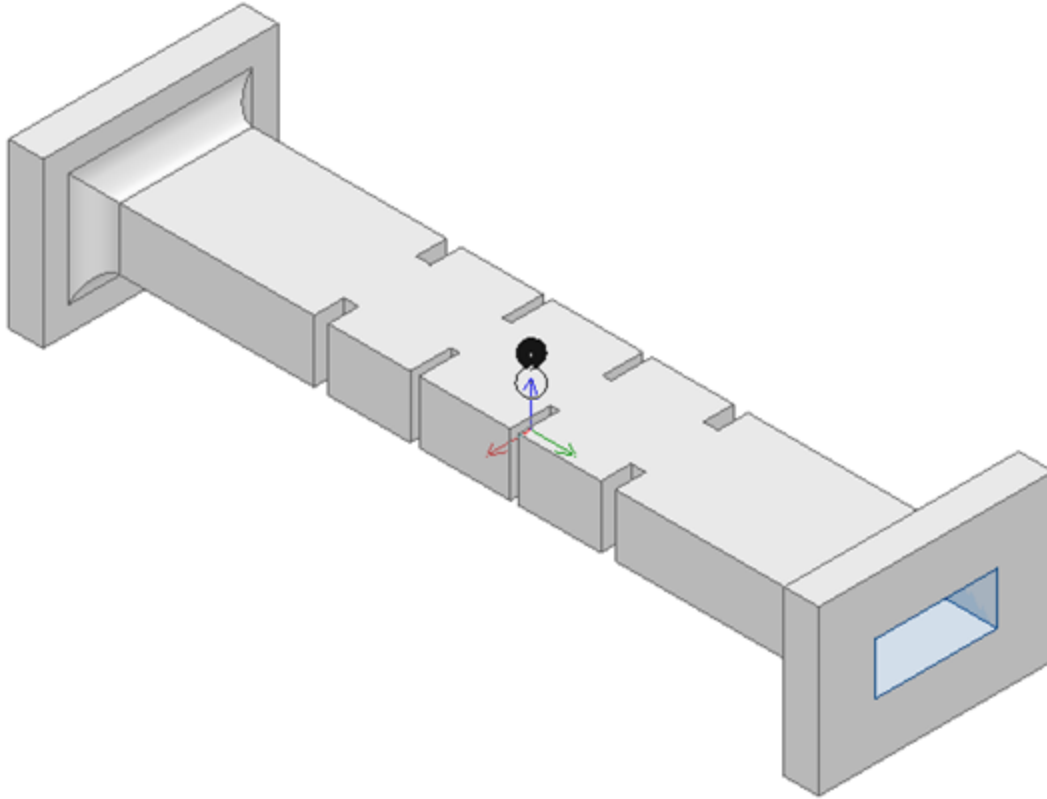

Figure 3-11: Point Selection

3. From the right-click menu, select **Assign Monitor > Point**.
4. In the **Monitor Setup** dialog box, select **Temperature** and click **OK**. The point monitor appears under **Monitor** in the **Project Manager**.

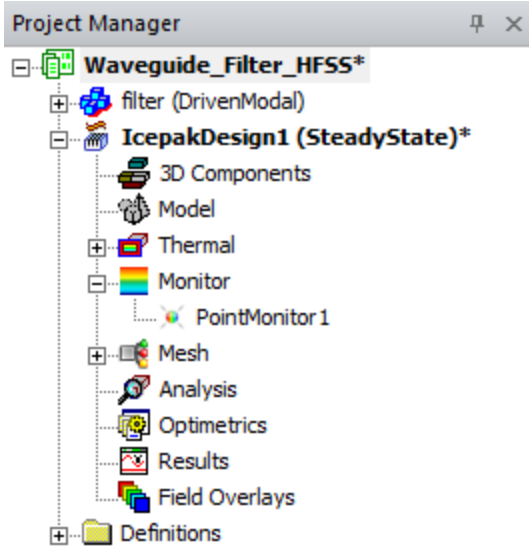

Figure 3-12: Project Manager - Monitor

Define Icepak Design Settings

Specify the project design settings as follows:

1. Click **Icepak>Design Settings**.

The **Design Settings** dialog box appears.

2. Click through the tabs and review the settings. Retain the default values on and click **OK**.

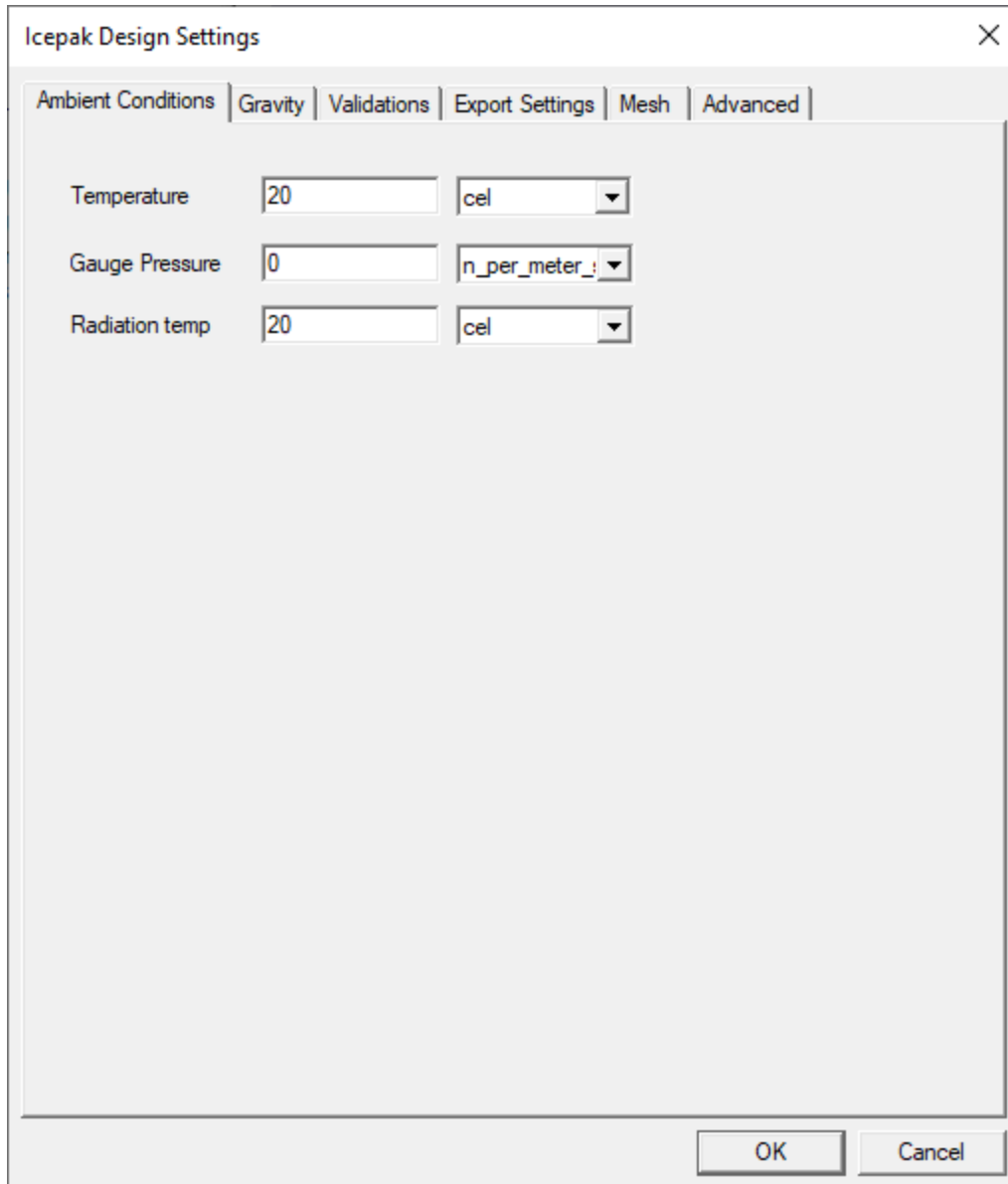

Figure 3-13: Icepak Design Settings dialog box

Add a Solution Setup

Prior to generating a mesh, you must create a solution setup, in which you specify general and solution settings.

1. In the **Project Manager**, right-click on **Analysis** and select **Add Solution Setup**.
2. In the **Icepak Solve Setup Dialog** under **Flow Regime**, select **Turbulent** and click **Options**.
3. In the **Turbulent Flow Model** dialog box, retain the default selection of **Zero Equation** and click **OK**.
4. Select **Include Gravity**.
5. On the **Solver Settings** tab, enter 1 as the **Y Velocity** initialization and retain the unit **m_per_sec**.
6. Click **OK** to save the settings. The solution setup is added under **Analysis** in the **Project Manager**.
7. From the **File** menu, click **Save**.

Generate a Global Mesh

When the model geometry is finished, you can mesh the model. In this example, you'll create an initial global mesh using the intermediate Auto Mesh Setting.

View Global Mesh Settings

1. In the **Project Manager**, right-click on **Mesh** and select **Edit Global Region**.
2. In the **Mesh Region** dialog box, examine the default mesh settings on the **General** and **Advanced** tabs.
3. Retain the default settings and click **OK**.

Generate and Examine the Mesh

1. On the **Simulation** ribbon, click **Generate Mesh**. When the mesh operation is complete, the mesh loads and the **Mesh visualization** dialog box appears.
2. In the **Mesh visualization** dialog box under **Mesh display on**, select **Show** to display the mesh if it is not already enabled.
3. On the **View** ribbon, click the **Isometric** orientation option  from the **Orient** drop-down list and then click **Fit All**.

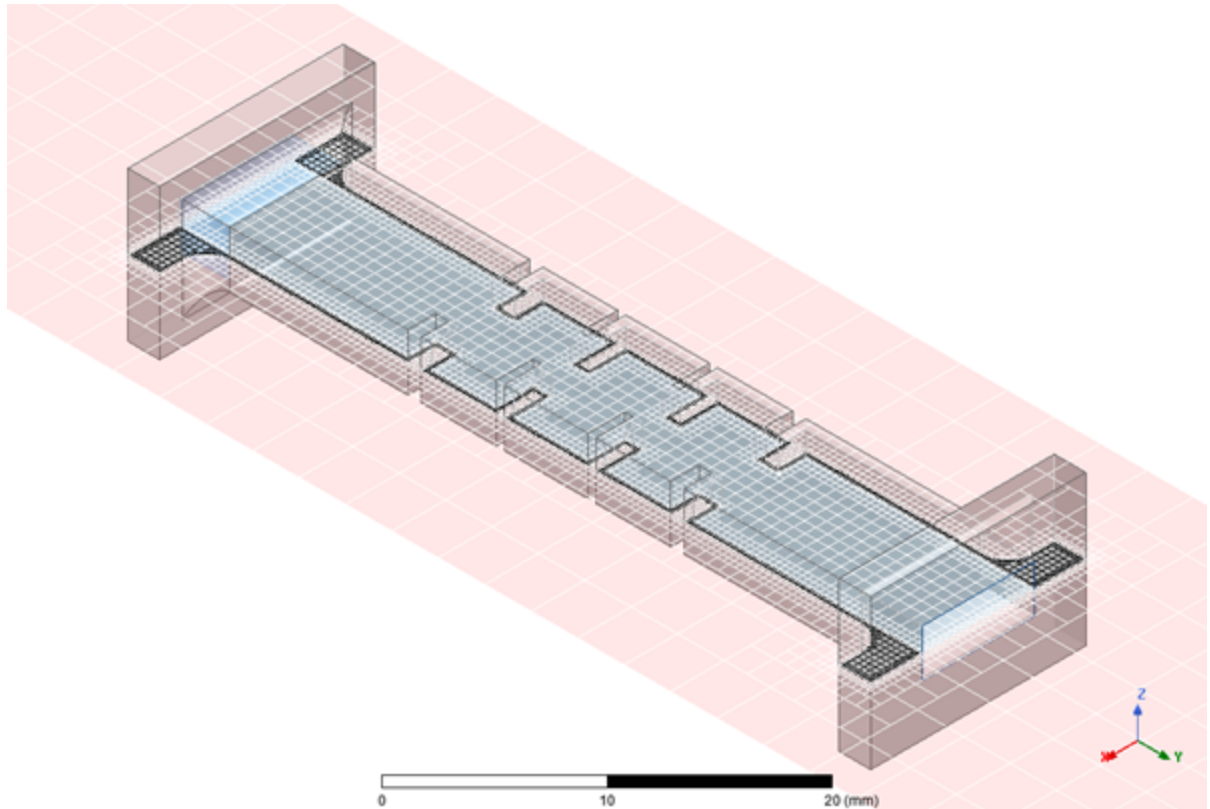

Figure 3-14: Initial Global Mesh

4. In the **Mesh visualization** dialog box, click the **Quality** tab and toggle between **Face alignment**, **Volume**, and **Skewness**, noting the **Min** value and **Max** value for each. Selecting a histogram bar will highlight those cells in the **3D Modeler** window.

Note: The following are targets value for face alignment and skewness that increase the probability of simulation convergence and accurate results.

- Face alignment: >0.05
 - Skewness: >0.02
5. Click **Close** to close the **Mesh visualization** dialog box.

Generate the Refined Mesh

Edit Global Mesh Settings

1. In the **Project Manager**, right-click on **Mesh** and select **Edit Global Region**.
2. Click and drag the **Auto Mesh Setting** slider bar to the finest setting (**Fine/Large**).
3. Click **OK**.

Generate and Examine the Mesh

1. In the **Project Manager**, right-click on **Mesh** and select **Generate Mesh**.
2. On the **Simulation** ribbon, click **Generate Mesh**. When the mesh operation is complete, the mesh loads and the **Mesh visualization** dialog box appears.
3. In the **Mesh visualization** dialog box under **Mesh display on**, select **Show** to display the mesh if it is not already enabled.
4. In the history tree, select *wg_flange_in*, *wg_flange_out*, and *wg_outer*.
5. On the **View** ribbon, click the **Isometric** orientation option  from the **Orient** and then click **Fit All**.

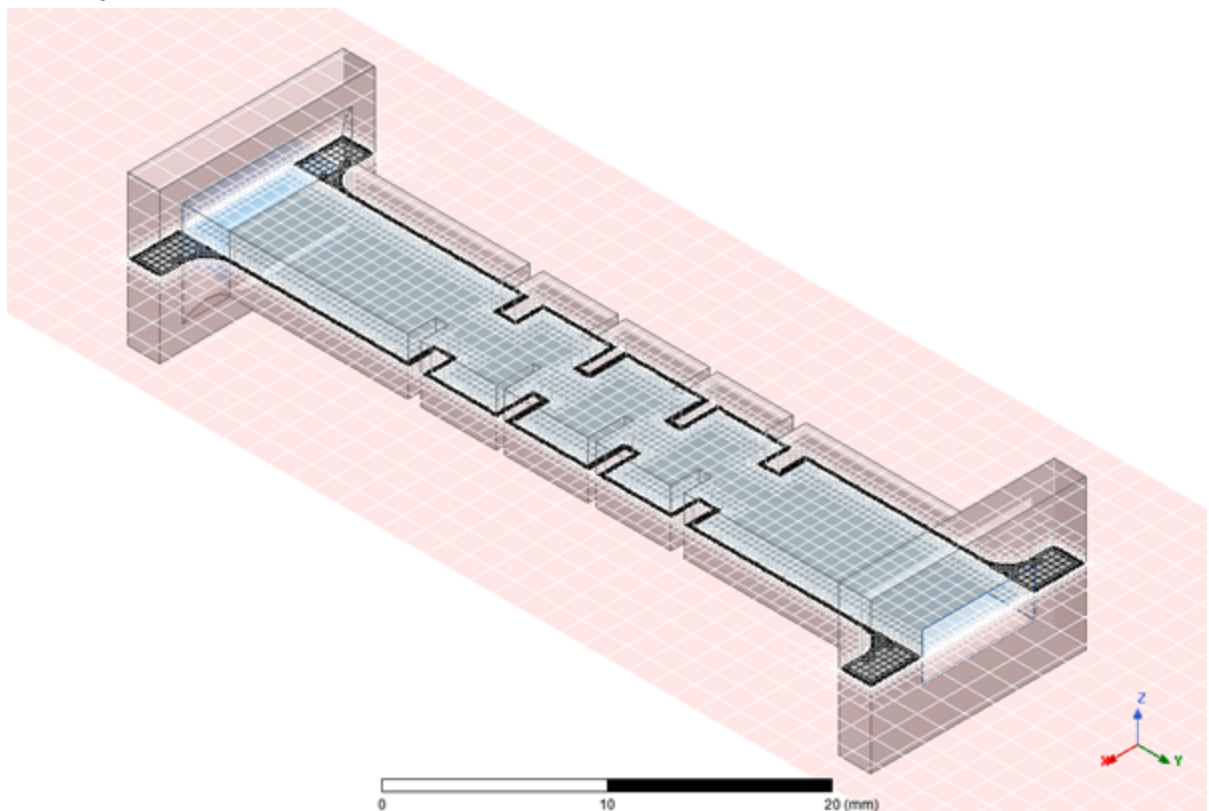

Figure 3-15: Refined Mesh

6. In the **Mesh visualization** dialog box, click the **Quality** tab and toggle between **Face alignment**, **Volume**, and **Skewness**, noting the **Min** and **Max** values for each.
7. Click **Close** to close the **Mesh visualization** dialog box.
8. From the **File** menu, select **Save**.

Run the Icepak Simulation

1. In the **Project Manager** under **Analysis**, right-click **Setup1** and select **Analyze**.
2. Right-click on **Setup1** again and select **Residual** to open the **Solutions** dialog box, where you can view the solution residuals as they are updated with each iteration.

Note: You can double-click on the x-axis to open the **Properties** dialog box. You can select the **X Scaling** tab and edit the display properties.

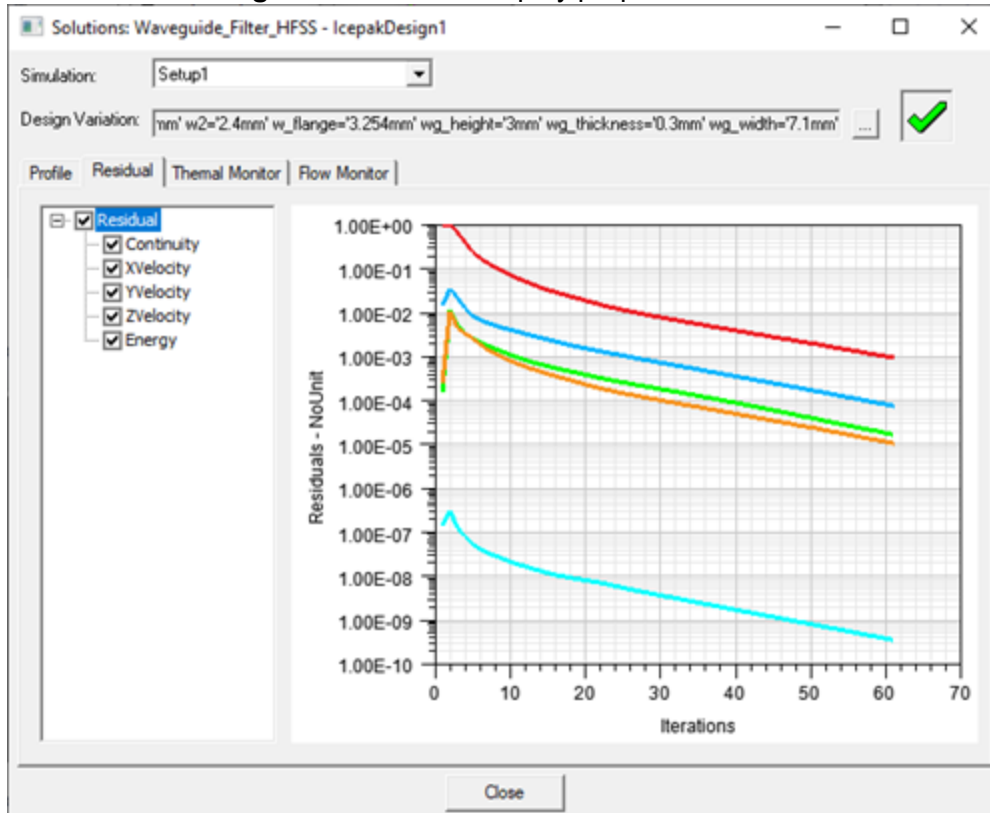

Figure 3-16: Solutions Dialog Box - Residual tab

3. Click the **Thermal Monitor** tab and review the monitor data.

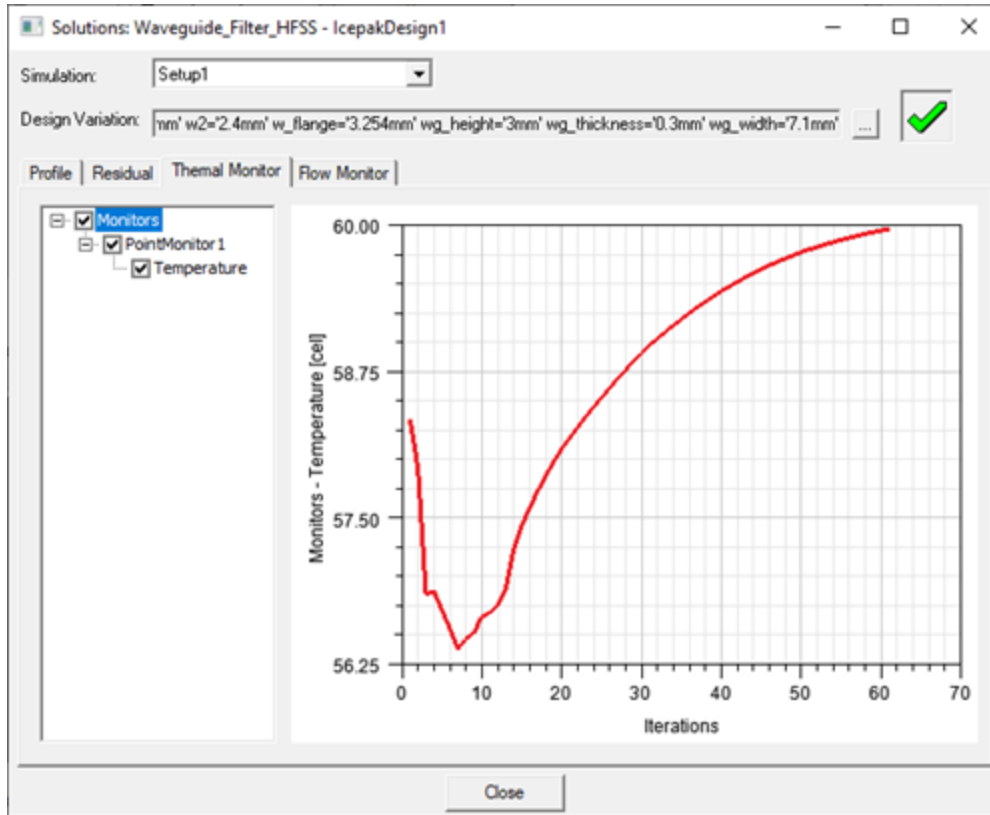

Figure 3-17: Solutions Dialog Box - Thermal Monitor tab

4. Click the **Profile** tab and review the EM loss data.

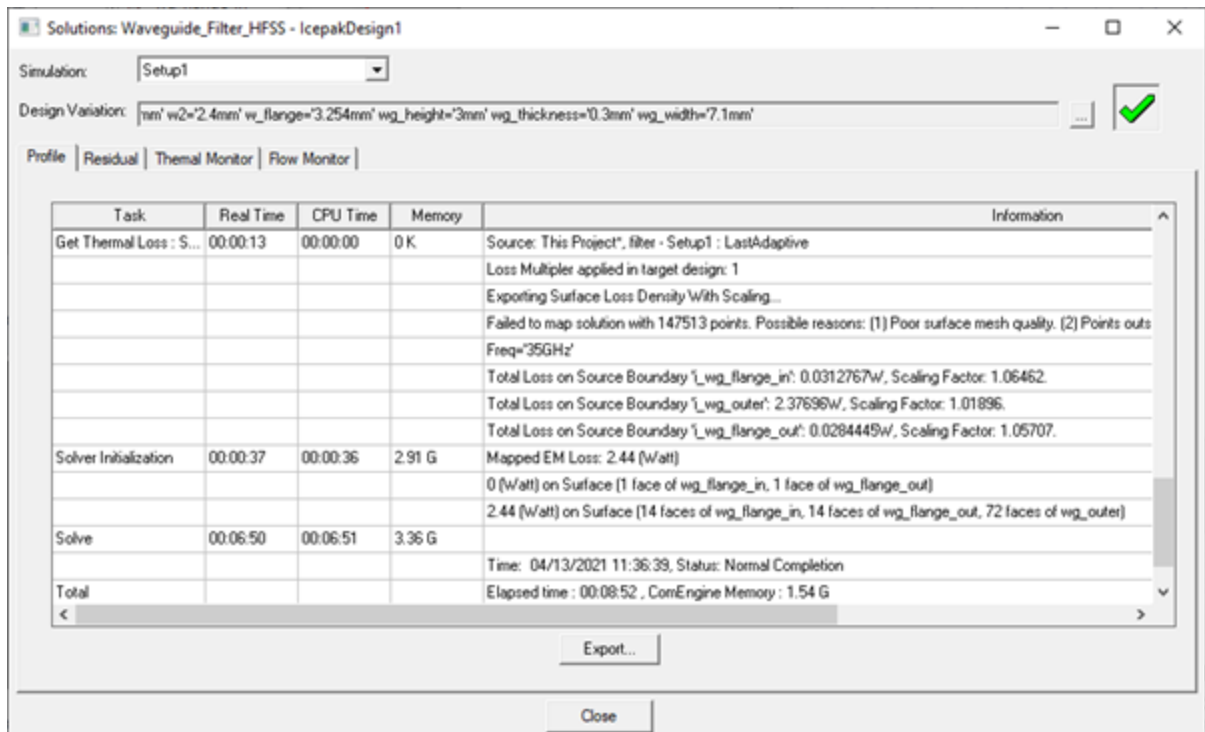

Figure 3-18: Solutions Dialog Box - Profile tab

5. Click **Close**.

4 - Postprocess the Icepak Simulation

This chapter contains the following topic:

- [Create Field Plots](#)
- [Create a Fields Summary](#)

Create Field Plots

Create a Temperature Field Plot

1. On the **View** ribbon, click the **Top** orientation option  from the **Orient** drop-down list and then click **Fit All**.
2. In the history tree, select *wg_flange_in*, *wg_flange_out*, and *wg_outer*.
3. Right-click on the selection and select **Plot Fields** > **Temperature** > **Temperature**.
4. In the **Create Field Plot** dialog box, retain the default selections under **Quantity** and **In Volume**.
5. Select the **Plot on surface only** check box.
6. Click **Done**.
7. Right-click on the **Temperature** legend and select **Modify**.
8. On the **Scale** tab under **Number Format**, select **Decimal** for **Type** and enter 6 for **Width**.
9. Click **Set as default** and then **Close**.

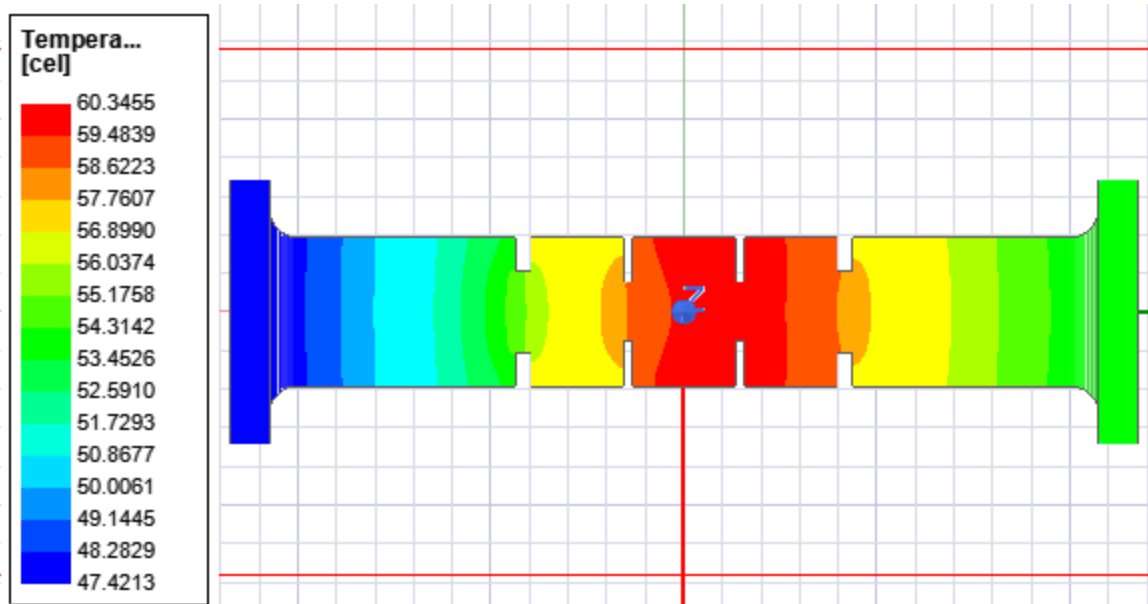

Figure 4-1: Temperature Field Plot

Create a Velocity Field Plot

1. In the history tree, expand **Planes** and select **Global: XY**.
2. Right-click in the **3D Modeler** window and select **Plot Fields > Velocity > Velocity Vectors**.
3. In the **Create Field Plot** dialog box, retain all of the default selections and click **Done**.

Note: Click and drag the **Velocity** colorkey to also display the **Temperature** colorkey.

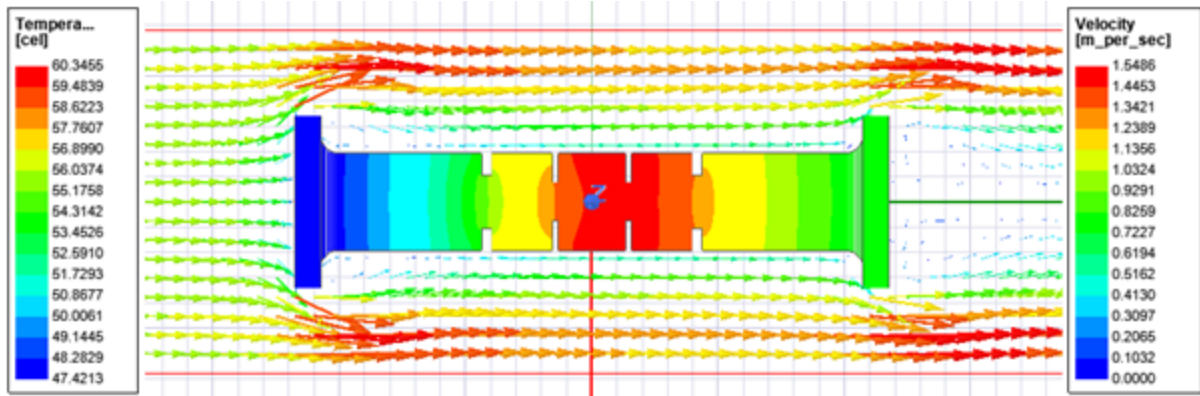

Figure 4-2: Velocity and Temperature Field Plots

Create a Fields Summary

Verify the energy balance using the Fields Summary report. The mapped loss is the only source of heat for the model. For a well converged solution, the heat dissipated from the system should be very close to the heat generated in the system.

1. On the **Results** ribbon, click **Fields Summary**.
2. In the **Setup Calculation** dialog box under **Entity**, select **Inlet** and **Outlet**.
3. Under **Quantity**, select **HeatFlowRate**.
4. Under **Side**, select **Adjacent**.

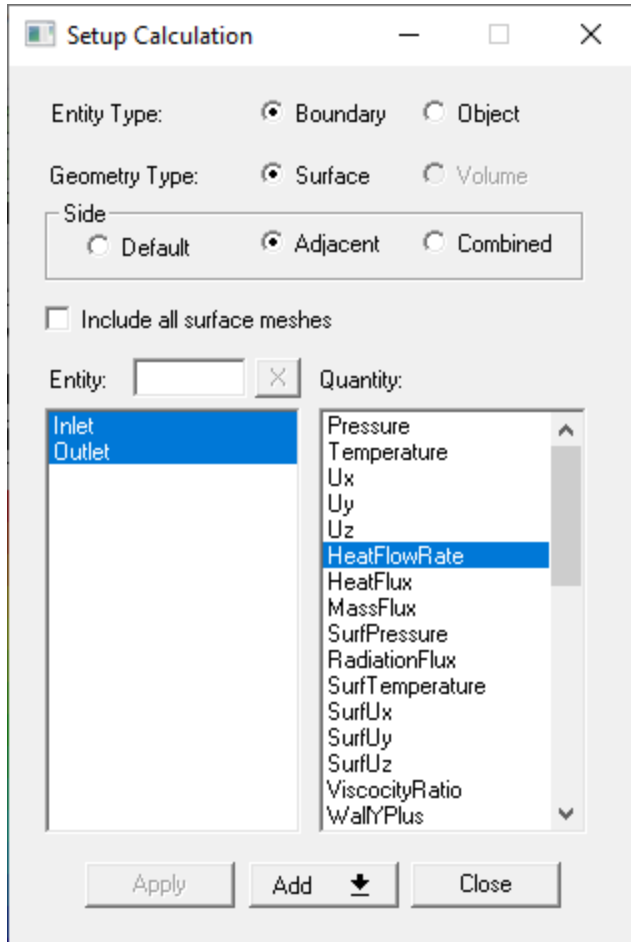

Figure 4-3: Setup Calculation

5. Click the **Add** drop-down button and select **Add as a Single Calculation**.

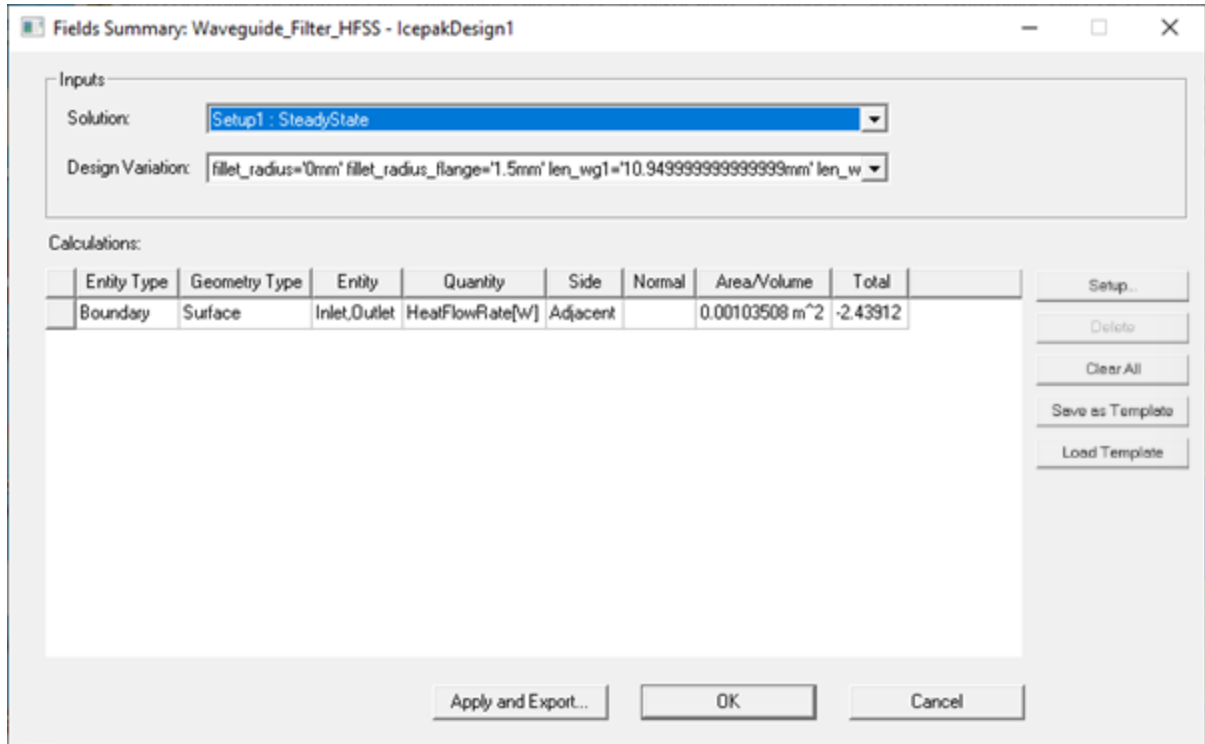

Figure 4-4: Fields Summary

Note: This is the total heat convected from the waveguide filter. Note that it matches the surface losses computed in HFSS (Fields Calculator) and the surface losses applied in the solver (Profile Monitor).